

# ISOLADORES SUSPENSOS

## FH – Isolador de Fibra de Vidro

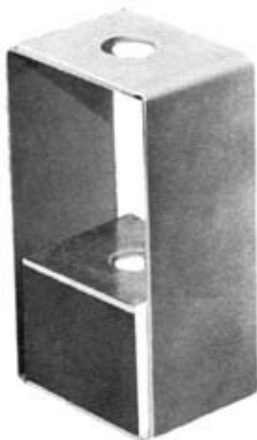

### Description

Kinetics Model FH hangers are recommended for use in isolating high frequency noise produced by suspended equipment, piping ductwork. FH Hangers incorporate a coded, molded, inorganic fiber glass isolation pad attached to a steel load transfer plate and to a stamped or welded hanger bracket. Hangers will allow a support rod misalignment through a 30° arc. Isolation brackets will carry 500% overload without failure. Fiber glass pads are fine (.00027" diameter) bonded annealed glass fibers which are stabilized by severely overloading the material during manufacture, and then coated with a flexible moisture-impervious elastomeric membrane. Fiber glass is unique in that the natural frequency is constant over a wide operating load range, and the stiffness increases proportionately with load applied. Model FH Fiber Glass Isolation Hangers are available in sizes with capacities from 250 to 900 lbs., with deflection of .18 to .27". Kinetics Model FH hangers are recommended for the isolation of vibration produced by suspended mechanical or electrical equipment, in-line and exhaust fans, ductwork, piping, etc.

### Application

Kinetics Model FH hangers are recommended for use in isolating any suspended source of audible frequency vibration, or noise, located near a critically quiet area.

Isolation of noise in piping and ductwork systems from a building structure is a typical use of Model FH hangers. Piping within 100 pipe diameters of connection to mechanical equipment should be isolated with Model SFH spring and fiber glass hangers to control transmission of low frequency vibration as well as noise.

High sound transmission loss ceiling systems can be effectively isolated by Model FH hangers. When isolating sources of predominately low frequency noise such as flyover aircraft, Model SFH hangers are recommended. Model FH hangers are shipped fully assembled and ready for installation in threaded rod suspension systems.

### Specifications

Vibration isolators with maximum static deflection requirements under the operating load conditions not exceeding .70" shall be hangers consisting of a precompressed molded fiber glass insert, complete with load transfer plate and assembled in a stamped or welded steel bracket.

The fiber glass insert shall be individually coated with a flexible, moisture-impervious elastomeric membrane. The insert shall be molded from glass fibers with fiber diameters not exceeding .00027" and with a modulus of elasticity of 10.5 million PSI.

Natural frequency of fiber glass vibration isolators shall be essentially constant for the operating load range of the supported equipment. Vibration isolators shall be coded to indicate load capacity.

The hanger bracket shall be designed to carry a 500% overload without failure and to allow a support rod misalignment through a 30° arc without metal-to-metal contact or other short circuit.

Isolation hangers shall be selected by the manufacturer for each specific application to comply with deflection requirements as shown on the Vibration Isolation Schedule or as indicated on the project documents.

Vibration isolation assembly shall be Model FH, as manufactured by Kinetics Noise Control, Inc.

**KINETICS NOISE CONTROL**  
**FH-250A/500A**

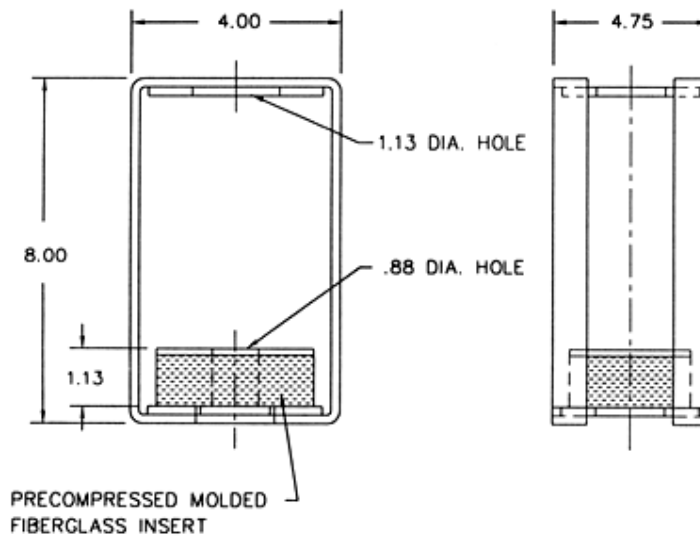

Hanger Model	Rated Load Pounds	Rated Defl. in
FH-900C	250/900	.18



Kinetics Noise Control, Inc. is continually upgrading the quality of our products. We reserve the right to make changes to this and all products without notice.