

ISOLADORES SUSPENSOS

SFH-4 – Mola e fibra de vidro “heavy”



BOLETIM B03KNC13SFH-4



Description

Kinetics Model SFH Vibration Isolation Hangers consist of free-standing, large diameter, laterally stable steel springs in series with a precompressed molded fiber glass insert assembled into a stamped or welded hanger bracket. Hangers incorporate a high deflection, color-coded spring element and a fiber glass isolator complete with load plate. To assure stability, the spring element has a minimum lateral spring stiffness of 1.0 times the rated vertical stiffness. Springs are epoxy powder coated, with a 1000 hour salt spray rating per ASTM B-117. Hangers will allow support rod misalignment through a 30° arc without short circuiting. Isolation brackets will carry a 500% overload without failure. Model SFH hangers are superior to hangers which incorporate a spring only, that can transmit noise through the all-metal construction, and hangers incorporating noise stop pads only, that can transmit low frequency vibration which a spring can isolate. Hangers are available in deflections 4.10" to 4.40" (104 to 112 mm) and in capacities from 100 to 3850 lbs. (46 to 1747 kg). Kinetics Model SFH combination hangers are recommended for the isolation of vibration produced by suspended mechanical equipment, low speed suspended fans, transformers, ductwork, piping, etc.

Application

Kinetics Model SFH hangers are recommended for use near critically quiet areas for isolating any suspended source of both audible and inaudible noise and vibration. Suspended mechanical equipment such as in-line fans cabinet fans, and piping and ductwork in close proximity to mechanical equipment are typical uses of Model SFH hangers.

Standard Model SFH hangers are shipped fully assembled and ready for installation in threaded rod suspension systems.

Model SFH hangers are available in a wide range of load and static deflection selections, and can be provided with labor saving accessories for adaptation to wire or strap suspension systems, and may be preloaded, or provided with plates for ease in erecting piping at a fixed elevation.

Specifications

Vibration isolators for suspended equipment with minimum static deflection requirement exceeding 0.4" (10 mm), and where both high and low frequency vibration is to be isolated, shall be hangers consisting of a laterally stable steel spring in series with a precompressed molded fiber glass insert complete with load plate and assembled in a stamped or welded steel bracket.

The bracket shall be finished with an epoxy-based powder coating. The manufacturer shall provide independent laboratory testing showing that the bracket with this finish has endured a minimum of 1,000 hours of exposure to salt spray fog testing per ASTM B117 without signs of corrosion.

The fiber glass insert shall be individually coated with a flexible, moisture-impervious elastomeric membrane. The insert shall be molded from glass fibers with fiber diameters not exceeding 0.00027" (6.8 microns) and with a modulus of elasticity of 10.5 million PSI (738,223 kg/sq. cm).

Natural frequency of fiber glass vibration isolators shall be essentially constant for the operating load range of the supported equipment.

The spring element shall have a minimum lateral stiffness of 1.0 times the rated vertical stiffness.

Vibration isolators shall be color coded or otherwise identified to indicate load capacity.

The hanger bracket shall be designed to carry a 500% overload without failure and to allow support rod misalignment through a 30° arc without metal-to-metal contact or other short circuit.

Isolation hangers shall be selected by the manufacturer for each specific application to comply with deflection requirements as shown on the Vibration Isolation Schedule or as indicated on the project documents.

The combination isolation hanger assembly with fiber glass insert shall be Model SFH, as manufactured by Kinetics noise Control, Inc.

SFH-4-100/1600

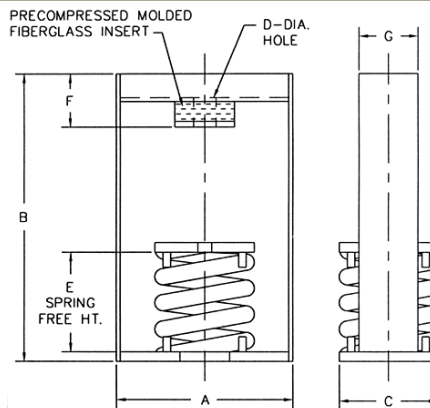

Spring Type	Spring Color	Rated Defl. in/mm	Rated Load lb/kg	A in/mm	B in/mm	C in/mm	D in/mm	E in/mm	F in/mm	G in/mm
SFH-4-100	Gray	4.06/103	100/46	9.38/238	16.00/406	6.00/152	1.13/29	10.00/254	2.66/68	4.00/102
SFH-4-250	Blue	4.11/104	250/114	9.38/238	16.00/406	6.00/152	1.13/29	10.00/254	2.66/68	4.00/102
SFH-4-500	Green	4.15/105	500/227	9.38/238	16.00/406	6.00/152	1.13/29	10.00/254	2.66/68	4.00/102
SFH-4-750	Black	4.17/106	750/341	9.38/238	16.00/406	6.00/152	1.13/29	10.00/254	2.66/68	4.00/102
SFH-4-1000	Red	4.18/106	1000/455	9.38/238	16.00/406	6.00/152	1.13/29	10.00/254	2.66/68	4.00/102
SFH-4-1250	Brown	4.19/106	1250/568	9.38/238	16.00/406	6.00/152	1.13/29	10.00/254	2.66/68	4.00/102

SFH-4-2250/3850

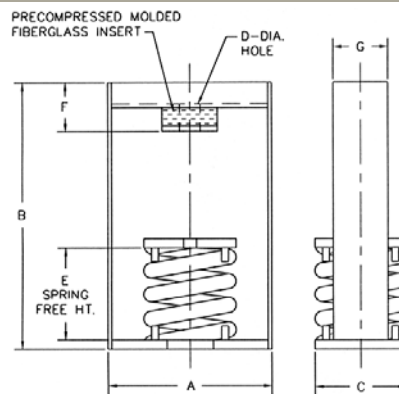

Spring Type	Spring Color	Rated Defl. in/mm	Rated Load lb/kg	A in/mm	B in/mm	C in/mm	D in/mm	E in/mm	F in/mm	G in/mm
SFH-4-2250	Beige	4.05/103	2250/1023	13.50/343	18.50/470	8.00/203	1.13/29	11.50/292	3.17/81	6.00/152
SFH-4-2500	Beige/Blue	4.06/103	2500/1136	13.50/343	18.50/470	8.00/203	1.13/29	11.50/292	3.17/81	6.00/152
SFH-4-2750	Beige/Grn	4.06/103	2750/1250	13.50/343	18.50/470	8.00/203	1.13/29	11.50/292	3.17/81	6.00/152
SFH-4-3000	Beige/Blk	4.07/103	3000/1364	13.50/343	18.50/470	8.00/203	1.13/29	11.50/292	3.17/81	6.00/152
SFH-4-3250	Beige/Red	4.08/104	3250/1475	13.50/343	18.50/470	8.00/203	1.13/29	11.50/292	3.17/81	6.00/152
SFH-4-3500	Beige/Brn	4.08/104	3500/1588	13.50/343	18.50/470	8.00/203	1.13/29	11.50/292	3.17/81	6.00/152